

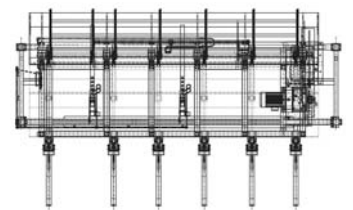

**GEMOFOR**  
FOR A WORLD OF PERFORMANCE

# GO-TILT

## Breakdown Tilt-Hoist

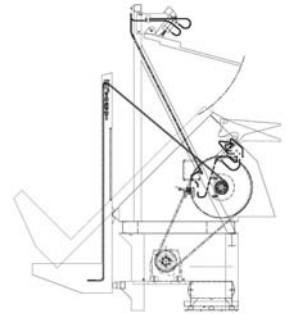

## FAST AND EFFICIENT

- Fast and efficient unstacking of lumber packages at the planer infeed.
- Heavy-duty construction with full plating of loading face.
- All electric operation with fail-safe braking on hoist.
- Custom built to handle one or two loads at a time.
- Standard load size: 4' to 8' wide by 8' to 24' in length.
- Manual or automatic operation.

### Options

- Self-levelling.
- Diverter panel for selecting stick or dunnage belt.
- Pneumatic hammer for frozen loads.

Now manufactured and sold by:

**CARBOTECH**   
INTERNATIONAL

### Main Office

2250, rue Saint-Jean  
Plessisville (Québec)  
Canada G6L 2Y4  
Phone: 819 362-6317  
Fax: 819 362-6166  
info@carbotech-intl.com  
www.carbotech-intl.com

### Doug Eubanks,

**U.S. Corporate manager**  
518 Grand Point Drive  
Hot Spring, AR 71901, USA  
Phone: 501 262-2169  
Fax: 501 262-4578  
Cell.: 501 282-3242  
dougaseubanks@earthlink.net

# GO-TILT

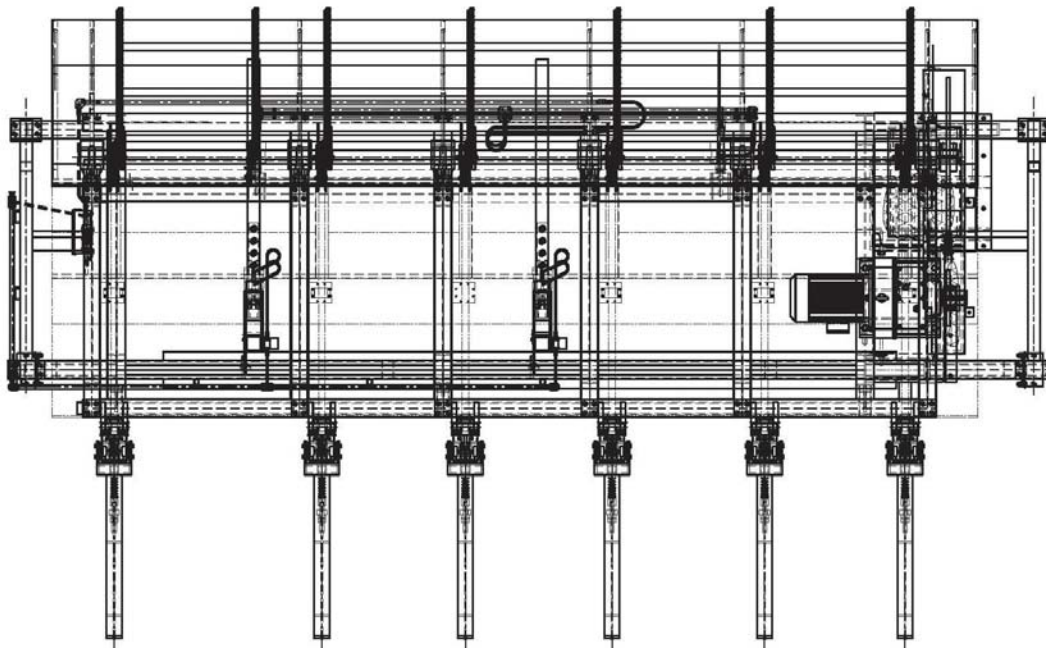
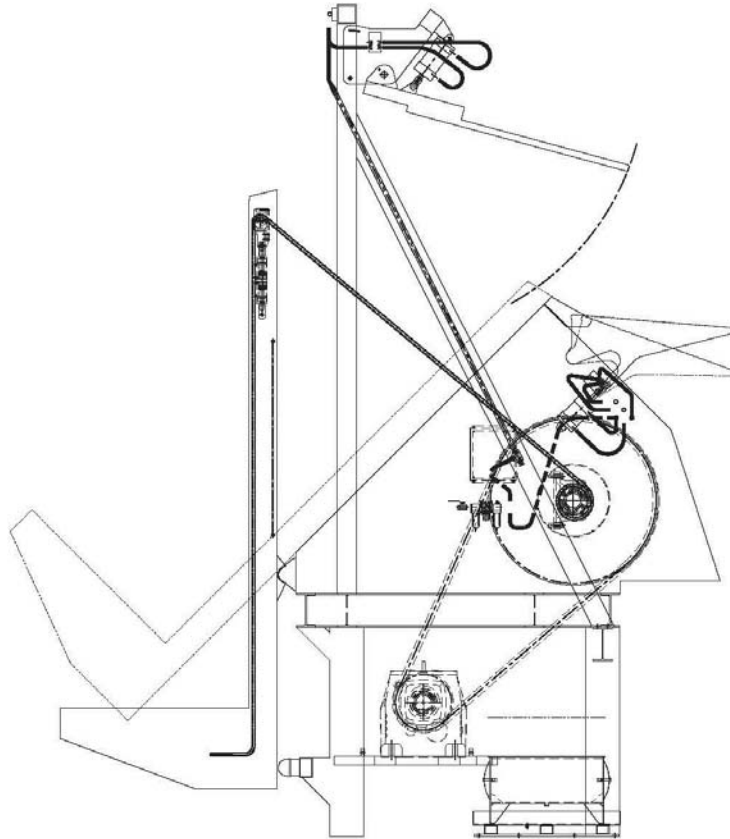

**GEMOFOR**  
FOR A WORLD OF PERFORMANCE