

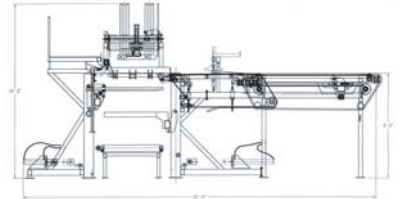

GEMOFOR
FOR A WORLD OF PERFORMANCE

GEM-O-STACK

Board Stacker



- Stacks lumber into loads for the kiln or finished packages at the planer.
- From 12 to 18 cycles per minute.
- Even-ending chain.
- Manual or automatic operation.
- Product sizes: 1" X 3" to 2" X 12", 4' to 24' in length.
- Bundle sizes: 2' to 8' high, 4' to 8' in width.

Options

- Secondary forks.
- Planer mill square-ender.

Now manufactured and sold by:

CARBOTECH
INTERNATIONAL 

Main Office

2250, rue Saint-Jean
Plessisville (Québec)
Canada G6L 2Y4
Phone: 819 362-6317
Fax: 819 362-6166
info@carbotech-intl.com
www.carbotech-intl.com

Doug Eubanks,

U.S. Corporate manager
518 Grand Point Drive
Hot Spring, AR 71901, USA
Phone: 501 262-2169
Fax: 501 262-4578
Cell.: 501 282-3242
dougaseubanks@earthlink.net

GEM-O-STACK

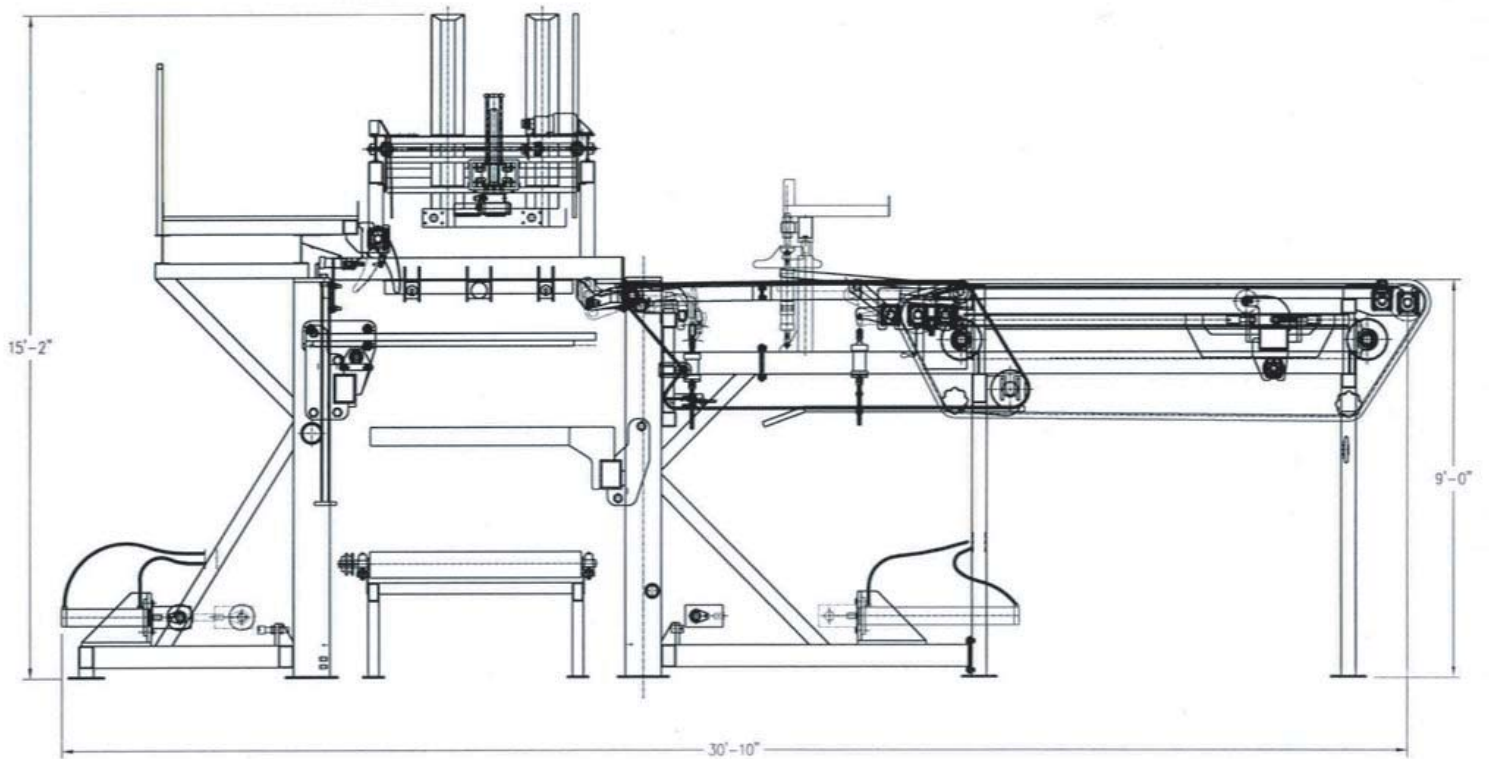

GEMOFOR
FOR A WORLD OF PERFORMANCE