

GIXI-M-3100

Mechanical Lug Loader



GEMOFOR

FOR A WORLD OF PERFORMANCE



For a world of performance

The GIXI-M-3100 Mechanical Lug Loader offers many features both for planer mill and sawmill operations.

It is possible to handle board thicknesses varying from 1/2" to 3". It can also handle boards of 4" thick. It is the GIXI-M-4000 model.

Feeding with the GIXI-M-3100

- The mechanical GIXI-M-3100 offers the same basic mechanical characteristics as the electronic GIXI-E-4000, which is well known for its rapidity of execution; up to 180 pieces/minute. The number of moving mechanical pieces of that is minimum. The pusher rods system by pneumatic rotator eliminate the back effect of wood when there is a loading stop.

The GIXI-M-3100 Controller

- Simple and compact, the controller runs the pusher rods with the help of a wheel used as an encoder and with two (2) proximity switches. It is also possible to have free logs. At the planer mill, it is even possible to have one (1) free log out of two (2) to free a classifier of his work for a while.

Versatility

- The GIXI-M-3100 can be adapted to all length of wood. It can handle from 36" in length and it's always available in 8, 10, 12, 16 and 24 feet model.

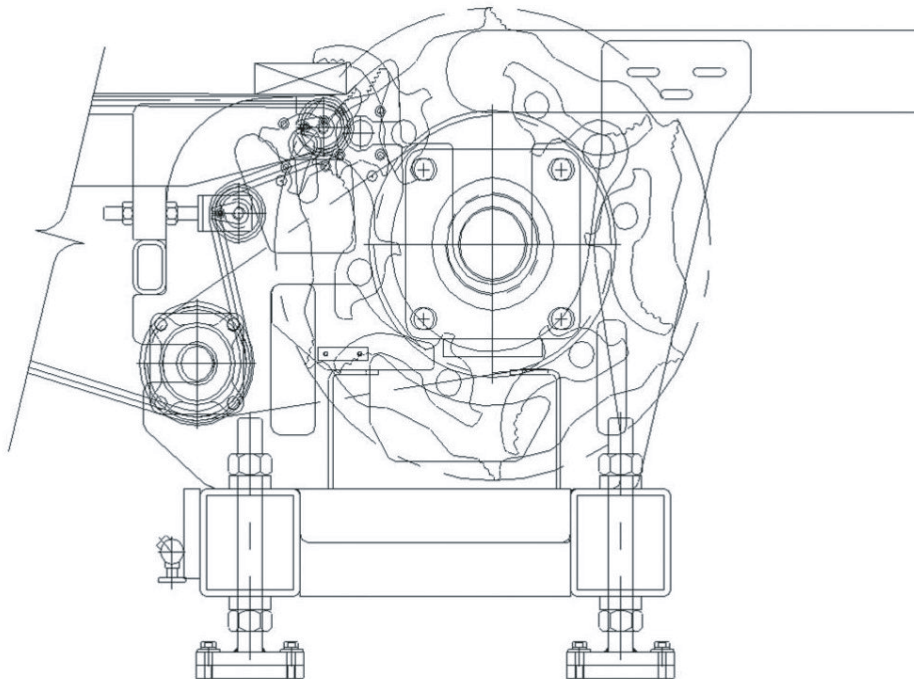

Now manufactured and sold by:

CARBOTECH
INTERNATIONAL

Main Office

2250, rue Saint-Jean
Plessisville (Québec)
Canada G6L 2Y4

Phone: 819 362-6317

Fax: 819 362-6166

info@carbotech-intl.com

www.carbotech-intl.com



GEMOFOR

FOR A WORLD OF PERFORMANCE

Doug Eubanks,
U.S. Corporate manager

518 Grand Point Drive

Hot Spring, AR 71901, USA

Phone: 501 262-2169

Fax: 501 262-4578

Cell.: 501 282-3242

dougaseubanks@earthlink.net