

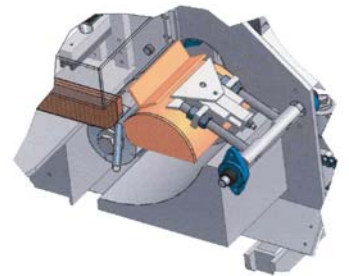

**GEMOFOR**  
FOR A WORLD OF PERFORMANCE

# G-RADIUS

## Manual Round Corner Shaper

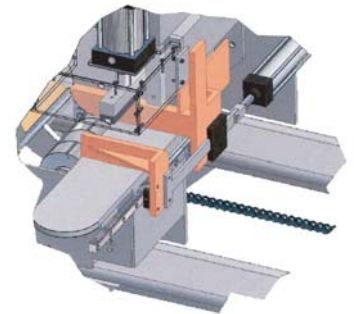
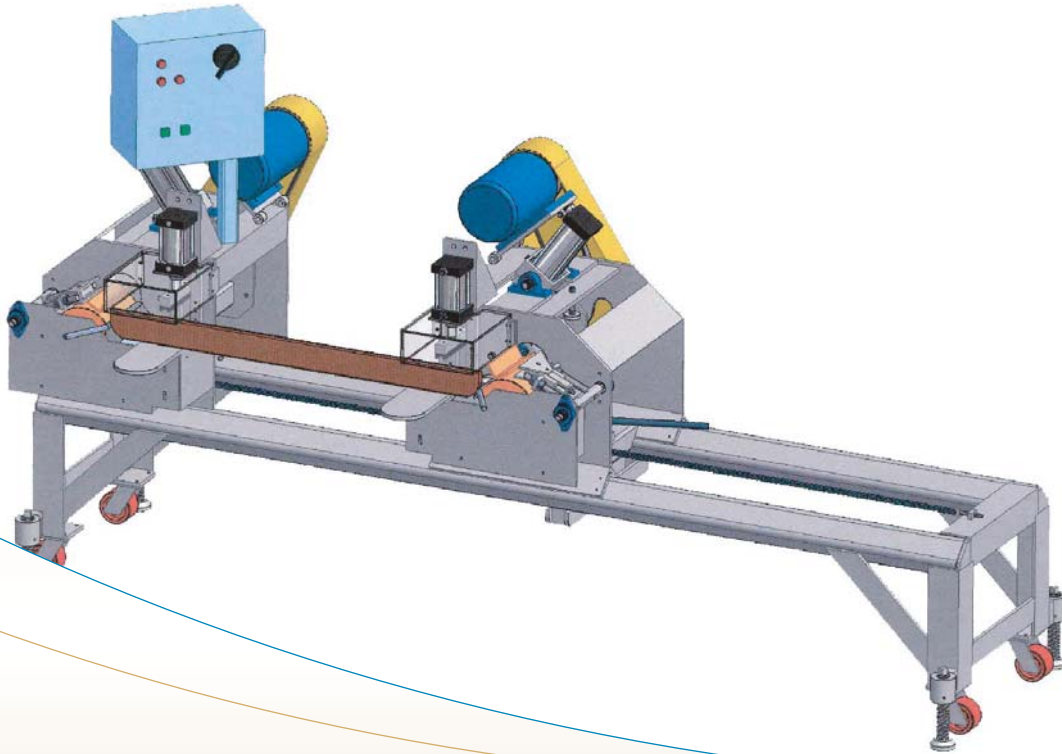

## AFFORDABLE, PERFORMANCE AND MALLEABILITY

Designed for very specific applications, such as bed structures and fence poles, GEMOFOR's round corner shaper leads to superior quality finished products.

Although entirely manual, this machine is very efficient and affordable. Built on rolls, it can be integrated to your line for the production of a specific product, and then taken out quickly.

### Advantages

- Knives:
  - Two heads with interchangeable knives.
- Motorization and pedal:
  - Mounted on pneumatic cylinder.
- Security box:
  - On ball bearing.
  - Moves with the heads.

### Specifications

- 1 to 7 boards at a time.
- Semi-automatic charger on pneumatic cylinder allows for external pre-piling, and then safely starts operating.
- Up to 10 cycles/minute.
- Displacement rolls.
- Knife's diameter: 5,9".
- Knife's width: three knives for a total of 5,9".
- Number of knives per head: 4.
- Operation speed: from 10 to 15 cycles/minute.

Now manufactured and sold by:

**CARBOTECH**  
INTERNATIONAL 

### Main Office

2250, rue Saint-Jean  
Plessisville (Québec)  
Canada G6L 2Y4  
Phone: 819 362-6317  
Fax: 819 362-6166  
info@carbotech-intl.com  
www.carbotech-intl.com

### Doug Eubanks,

**U.S. Corporate manager**  
518 Grand Point Drive  
Hot Spring, AR 71901, USA  
Phone: 501 262-2169  
Fax: 501 262-4578  
Cell.: 501 282-3242  
dougaseubanks@earthlink.net